



# Rulang Primary School

## END OF YEAR EXAMINATION SCIENCE 2025

Name: \_\_\_\_\_ ( )

Marks: \_\_\_\_\_ / 60

Level: Primary 5

Total Time for Booklets

Class: Primary 5 ( )

A and B: 1 h 45 min

Date: 23 Oct 2025

Total Marks:

100

### BOOKLET A

#### Instructions to pupils:

1. Do not open this booklet until you are told to do so.
2. You are required to answer **all** the questions in this booklet.
3. This question booklet consists of **20** printed pages, including the cover page.

**Section A (30 x 2 marks)**

For each question from 1 to 30, four options are given. One of them is the correct answer. Make your choice (1, 2, 3 or 4) and shade your answer on the Optical Answer Sheet.

1. Which of the following statements about cells are true?

- A: A cell is the basic unit of life.
- B: Non-living things are made up of cells.
- C: Different types of cells make up different body parts.
- D: Most cells are too small to be seen with the naked eye.

- (1) A and C only
- (2) B and D only
- (3) A, C and D only
- (4) A, B, C and D

2. The diagram below shows the cross-section of fruit P.

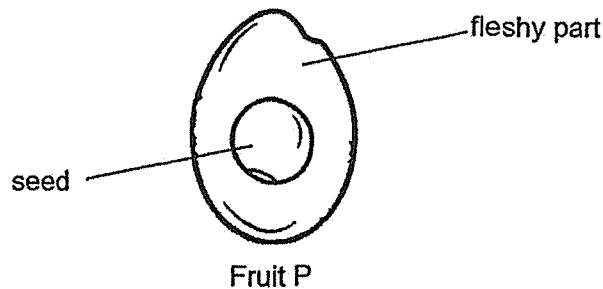

Which of the following statements are likely to be true about fruit P?

- A: The flower of P has many ovules.
- B: The flower of P has only one ovule.
- C: The seed of P is most likely dispersed by water.
- D: The seed of P is most likely thrown away when the fruit is eaten.

- (1) A and C only
- (2) A and D only
- (3) B and C only
- (4) B and D only

3. In the diagram below, K represents the processes during reproduction of a plant.

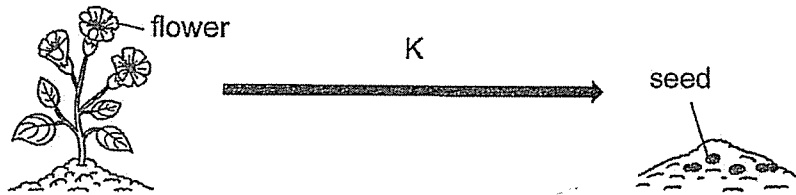

Which of the following processes does not take place at K?

- (1) pollination
  - (2) fertilisation
  - (3) germination
  - (4) seed dispersal
4. Sarah observed some characteristics of herself and her family members and drew the family tree shown below.

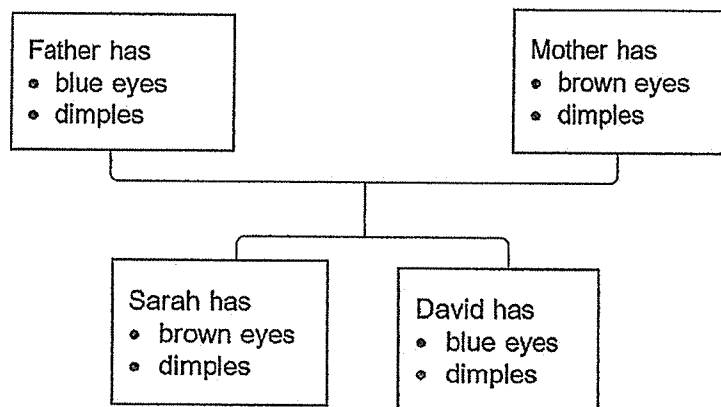

Which of the statements best explains Sarah's observations?

- (1) Children always look exactly like their parents.
- (2) Children inherit characteristics from only one parent.
- (3) Only physical features like height are passed from parents to children.
- (4) Eye colour and dimples are characteristics that can be inherited from parents.

5. Cheryl wanted to investigate if sunlight is needed for the germination of seeds using 2 set-ups. What variables must she keep the same in both the set-ups to make the experiment a fair test?

- A: Amount of soil
- B: Number of seeds
- C: Presence of sunlight ×
- D: Amount of water added to the soil

- (1) C only
- (2) A and B only
- (3) B and C only
- (4) A, B and D only

6. Three types of flowering plants, P, Q and R, were growing in area X as shown in diagram 1. Two years later, more P, Q and R were found growing in the fields as shown in diagram 2.

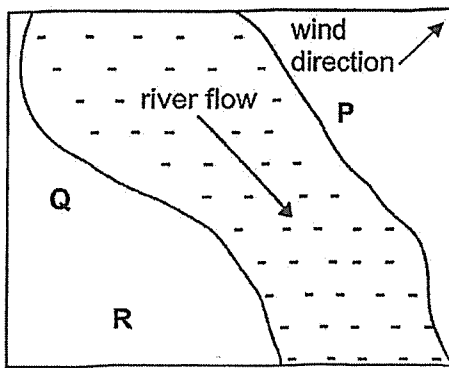

**Diagram 1**  
Area X at first

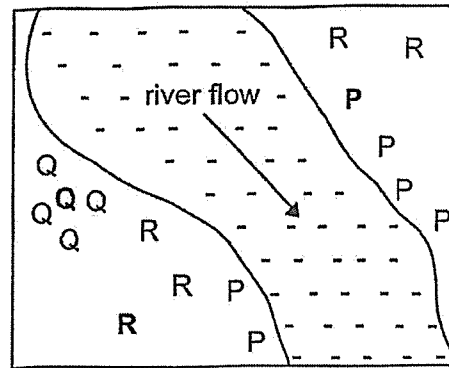
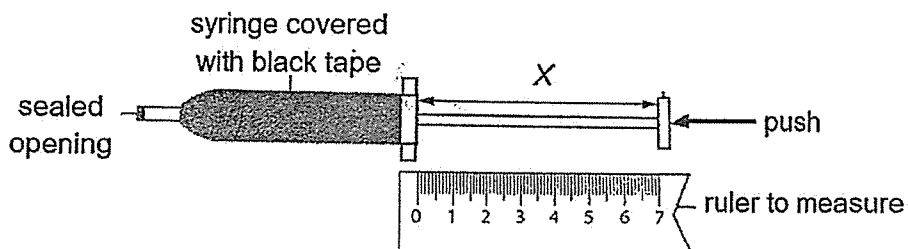

**Diagram 2**  
Area X two years later

Which of the following are the likely characteristics of the fruits / seeds of plants, P, Q and R?

	Fruit / seed of plant P	Fruit / seed of plant Q	Fruit / seed of plant R
(1)	fibrous husk	splits open when ripe	wing-like structure
(2)	fleshy and brightly coloured	hook-like structures	wing-like structure
(3)	splits open when ripe	fibrous husk	fleshy and brightly coloured
(4)	fibrous husk	wing-like structure	splits open when ripe

7. Three identical syringes were covered with black tape. Each of them contained different substances, A, B and C.



The distance  $X$  of each plunger was 7cm at first. The distance  $X$  was then measured and recorded below after the plunger was pushed with the same amount of force into all three syringes.

Substance	A	B	C
Distance $X$ before pushing (cm)	7	7	7
Distance $X$ after pushing (cm)	7	4	7

What could the states of A, B and C be?

	A	B	C
(1)	Solid	Gas	Liquid
(2)	Solid	Liquid	Gas
(3)	Liquid	Solid	Gas
(4)	Gas	Liquid	Solid

8. On a rainy morning, Marcus noticed that water droplets had formed on the inside of the glass windows of the school bus.

Which statement best explains this observation?

- (1) The air inside the bus was cooler than the air outside.
  - (2) The water droplets came from rainwater leaking through the glass.
  - (3) Cooler air outside the bus entered through the glass and formed droplets.
  - (4) Warm water vapour inside the bus came into contact with the cooler glass surfaces.
9. The graph below shows the changes in temperature of water when it is heated continuously.

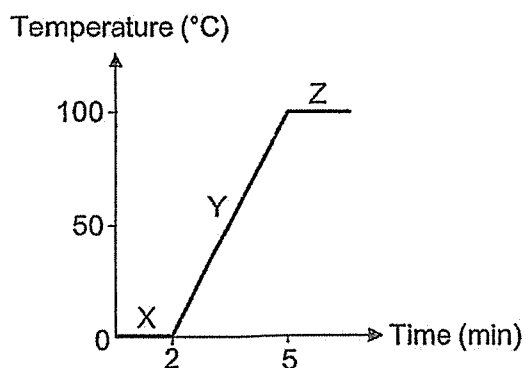

Based on the graph, which of the following is true?

- (1) Water is changed to steam at Z.
- (2) Evaporation only takes place at Y.
- (3) Freezing and melting take place at X.
- (4) The water begins boiling after two minutes.

10. Four containers, A, B, C and D, were each filled with 300ml of water. They were placed side by side in one corner of a room as shown below.

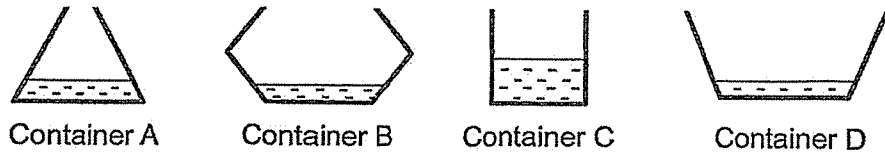

After 6 hours, the amount of water left in each container was measured.

Which of the following correctly shows the order of the containers from the most water left to the least water left in each container?

Most → Least

- (1) A, D, B, C
  - (2) A, C, B, D
  - (3) C, A, D, B
  - (4) D, B, C, A
11. Ryan wants to conduct an experiment to show that plants take in water through their roots. He has the following set-ups, P, Q, R and S, as shown below.

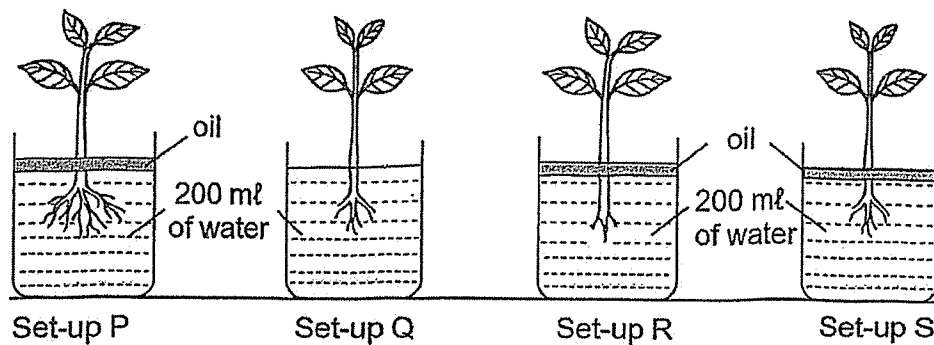

Which two set-ups should he use to carry out a fair test?

- (1) P and Q
- (2) P and R
- (3) Q and R
- (4) Q and S

12. The diagram below shows a river with factories and crops nearby.

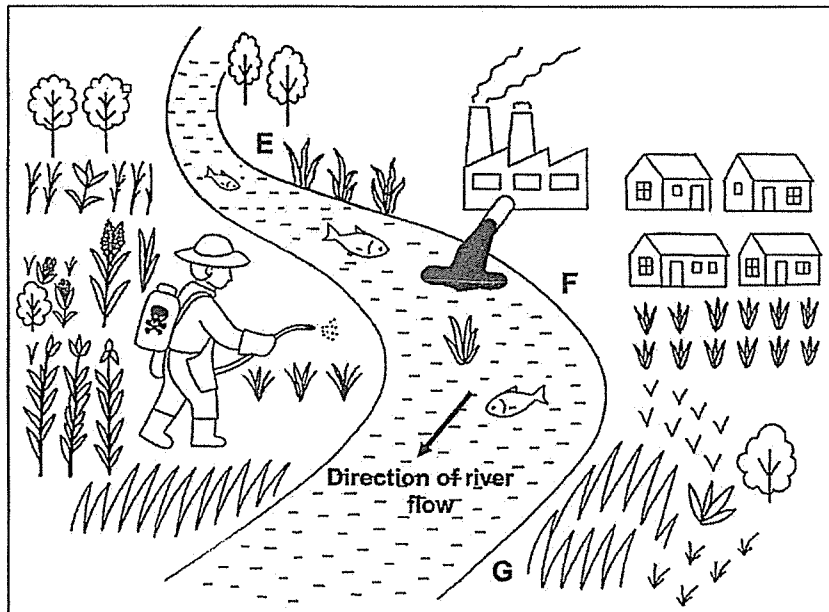

The following table shows the number of fish caught in different parts of the river and the amount of rice crops harvested from fields near each part in one day.

Part of river	Number of fish caught	Amount of rice harvested (kg)
E	30	50
F	10	25
G	0	15

Based on the table, which statement is ~~not~~ a possible conclusion?

- (1) Fish at E were the healthiest.
- (2) Polluted water at F harmed both the fish and crops.
- (3) Polluted water at G was the most harmful to the fish and crops.
- (4) Rice crops near the factories at F grew better than those near E.

13. Study the flowchart below.

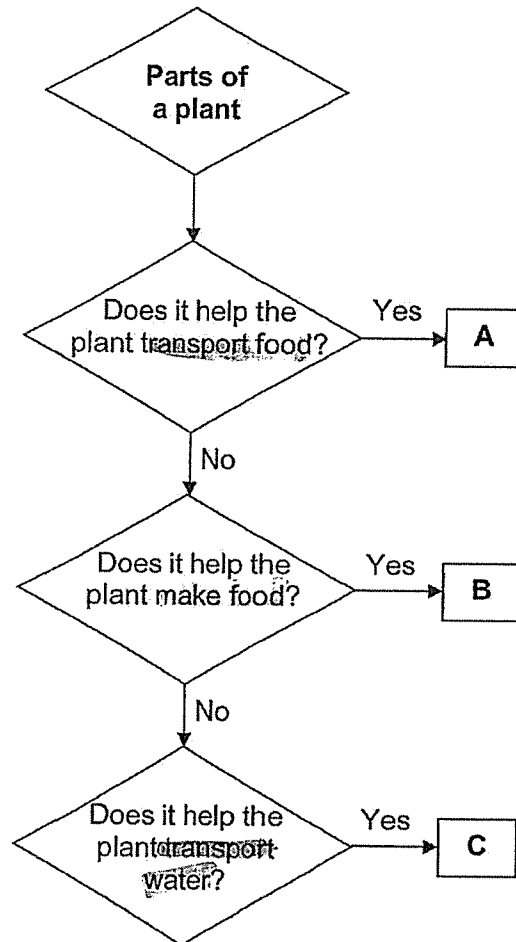

Which of the following correctly identifies A, B and C?

	A	B	C
(1)	Food-carrying tubes	Leaves	Roots
(2)	Food-carrying tubes	Leaves	Water-carrying tubes
(3)	Leaves	Food-carrying tubes	Water-carrying tubes
(4)	Leaves	Food-carrying tubes	Roots

14. A colony of ants were kept in a sealed container for an hour.

Which of the following shows the correct changes in the composition of air in the sealed container?

	Oxygen	Carbon dioxide
(1)	increased	decreased
(2)	decreased	increased
(3)	decreased	no change
(4)	no change	increased

15. The diagram below shows the direction of blood flow to and from the heart.

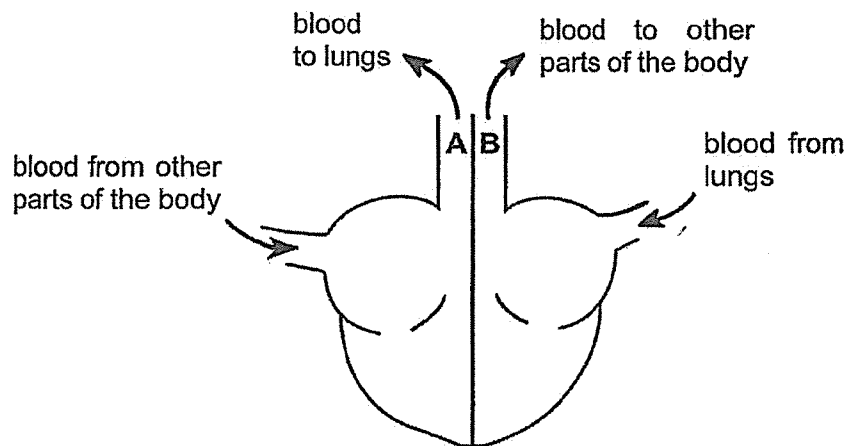

Which of the following correctly describes the blood in the blood vessels at A and B?

	A	B
(1)	rich in oxygen	rich in carbon dioxide
(2)	rich in oxygen	poor in carbon dioxide
(3)	rich in carbon dioxide	rich in oxygen
(4)	poor in carbon dioxide	rich in oxygen

16. Dalton wanted to find out if fruits could be used to light up a bulb. He set up his experiment as shown below.

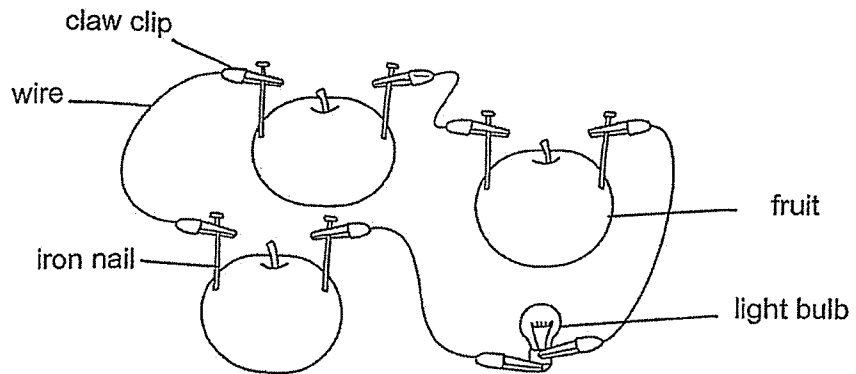

Dalton should set up another circuit using real batteries instead of fruits as a control for his experiment.

Which of the following circuits should be the control for his experiment?

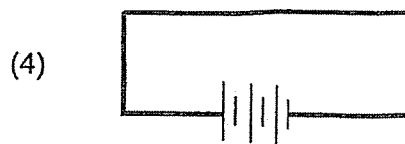
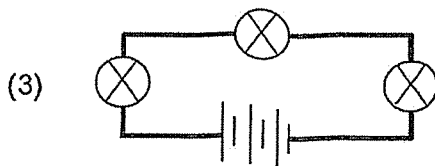
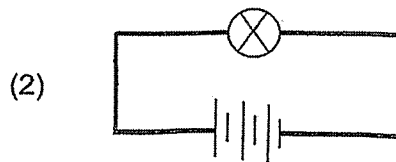
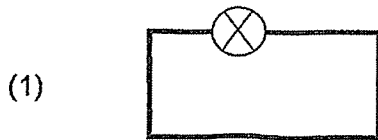

17. Study the diagram below.

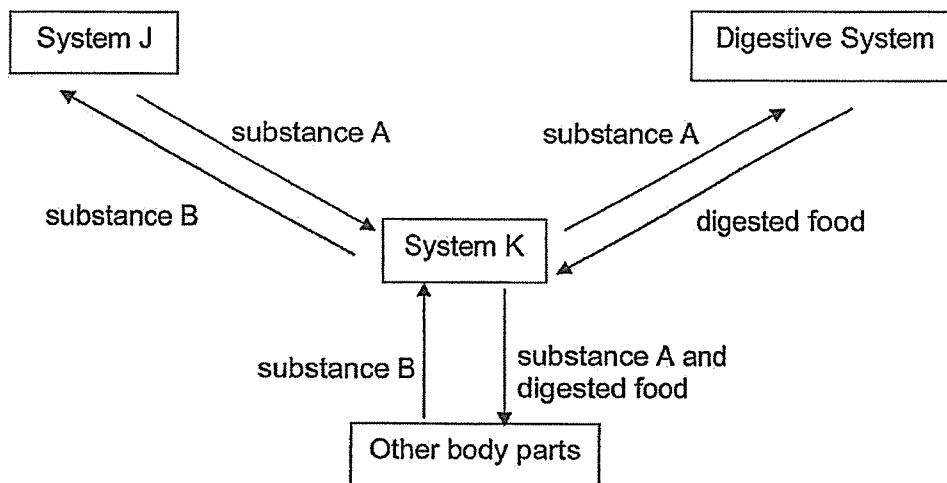

Which of the following correctly shows substances A and B and systems J and K?

	Substance A	Substance B	System J	System K
(1)	Oxygen	Carbon dioxide	Respiratory	Circulatory
(2)	Oxygen	Carbon dioxide	Circulatory	Respiratory
(3)	Carbon dioxide	Oxygen	Respiratory	Circulatory
(4)	Carbon dioxide	Oxygen	Circulatory	Respiratory

18. The circuit below has four bulb holders labelled A, B, C and D.

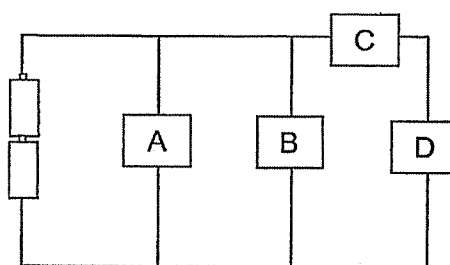

Two bulbs are fixed in the bulb holders such that both bulbs will light up. In which two bulb holders are the bulbs fixed?

- (1) A and B
- (2) A and D
- (3) B and C
- (4) B and D

Study the diagram below and answer questions 19 and 20.

A circuit is set up as shown below. Bulbs X and Y light up with equal brightness when the switch is closed.

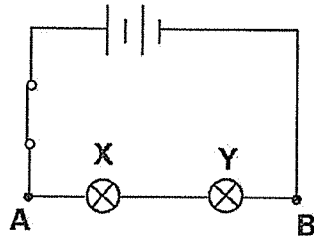

19. What will happen to the brightness of bulb X if one battery is removed and the circuit is closed?

- (1) It will not light up.
- (2) It will become brighter.
- (3) It will become dimmer.
- (4) It will remain the same.

20. Bulb Z is then connected to the circuit at A and B as shown below.

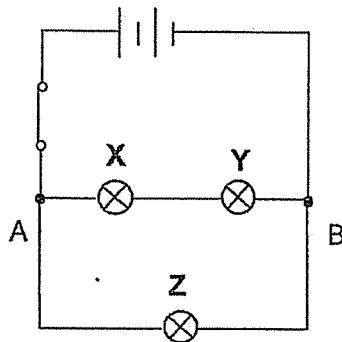

What will happen to the brightness of bulb X?

- (1) It will not light up.
- (2) It will become brighter.
- (3) It will become dimmer.
- (4) It will remain the same.

21. Caleb conducted an experiment using a circuit and recorded his results in a table shown below.

Switch P	Switch Q	Number of bulbs lit
Open	Open	0
Close	Open	0
Open	Close	1
Close	Close	2

Which of the following circuits did Caleb use?

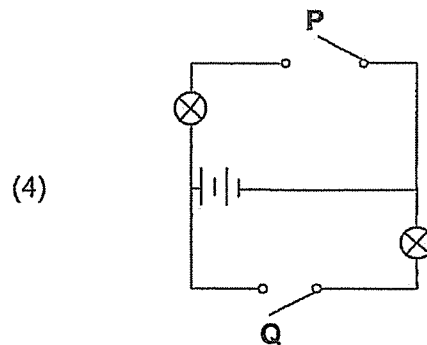
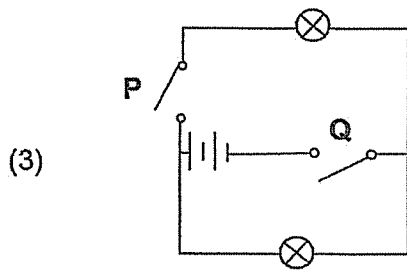
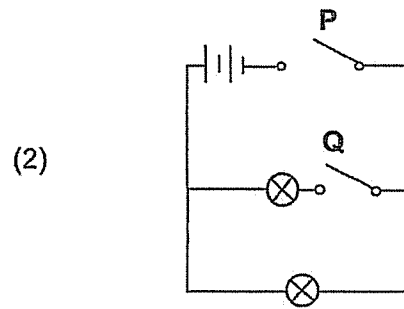
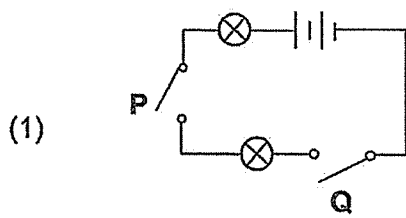

22. Gladys poured some water into a bottle through a funnel as shown below.

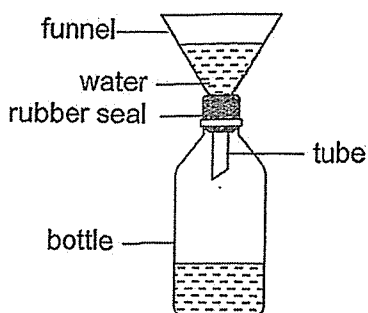

After a while, the water stopped flowing into the bottle.

Which of the following statements best explains why the water stopped flowing?

- (1) The bottle was already full of water.
- (2) The funnel tube was blocked by the water.
- (3) The water could not change its shape to fit the funnel.
- (4) Air trapped in the bottle prevented more water from entering.

23. The diagram below shows how some examples of matter are classified.

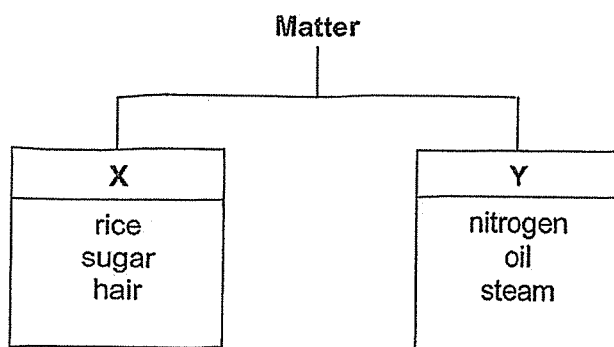

Which of the following correctly represents X and Y?

	<b>X</b>	<b>Y</b>
(1)	has mass	has no mass
(2)	has definite shape	has no definite shape
(3)	cannot be compressed	can be compressed
(4)	has definite volume	has no definite volume

24. Which of the following statements are correct about the human systems?

- A: The respiratory system helps transport food to all parts of the body.
- B: The muscular system works together with the skeletal system to help us move.
- C: The digestive system breaks down food into simpler substances that can be absorbed.
- D: The circulatory system carries oxygen and digested food to all parts of the body.

- (1) A and B only
- (2) A and C only
- (3) B and D only
- (4) B, C and D only

25. The graph shows the amount of undigested food in three different parts of the human digestive system.

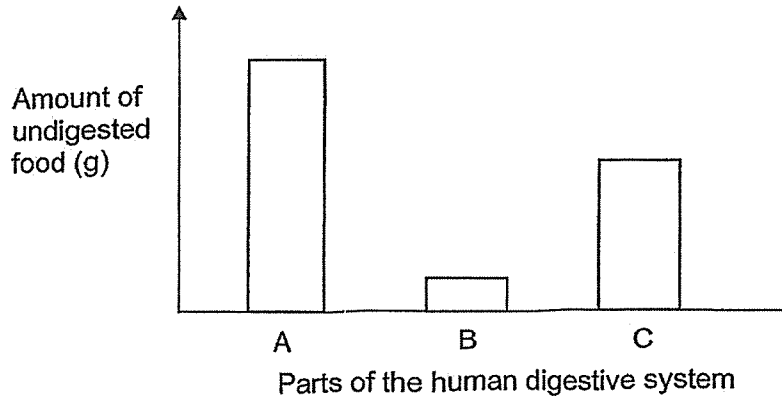

Which of the following correctly matches A, B and C to the parts of the human digestive system?

	A	B	C
(1)	small intestine	mouth	stomach
(2)	small intestine	stomach	mouth
(3)	mouth	small intestine	stomach
(4)	mouth	stomach	small intestine

26. Study the set-up below. A ball is placed between a screen and a torch.

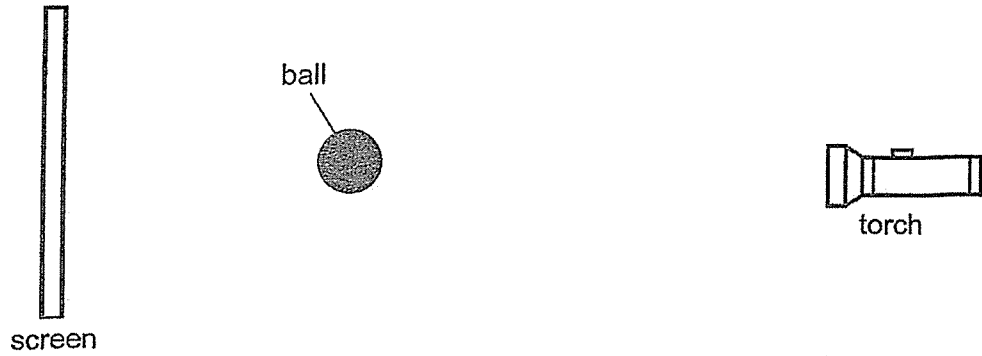

Which of the following changes will cause the shadow on the screen to become larger?

- (1) Move the ball closer to the torch.
- (2) Move the ball closer to the screen.
- (3) Move the screen closer to the ball.
- (4) Move the torch further from the screen.

27. Kayla was walking along the road at night from point A to D as shown below.

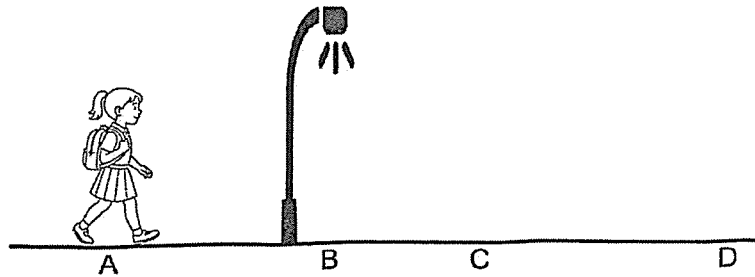

Which of the following graphs correctly shows the changes in the size of her shadow from positions A to D?

(1) Length of shadow (cm)

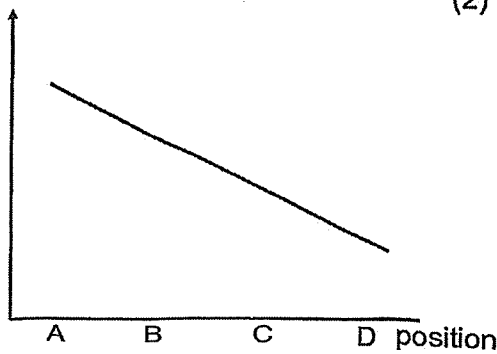

(2) Length of shadow (cm)

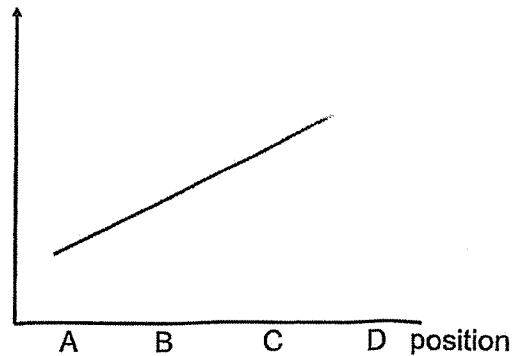

(3) Length of shadow (cm)

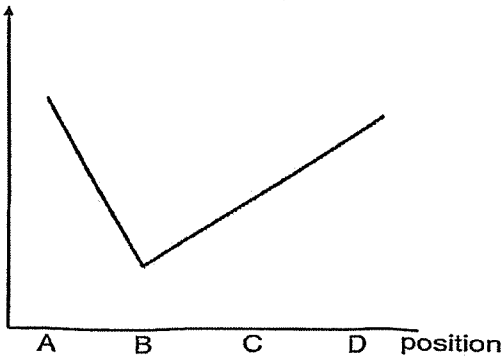

(4) Length of shadow (cm)

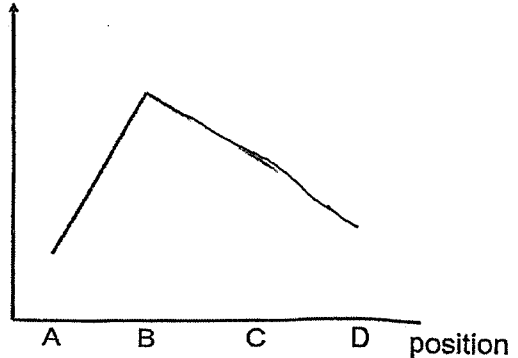

28. Three beakers, A, B and C, contain water at different temperatures. Metal strips are placed in between the beakers as shown below. The arrows show the direction of heat flow through the strips.

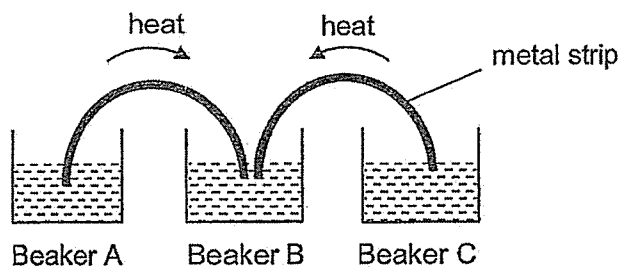

What can you conclude about the temperature of the water in beaker B compared to the other beakers?

- (1) The water in beaker B has the lowest temperature.
  - (2) The water in beaker B has the highest temperature.
  - (3) The water in beaker B has the same temperature as the water in beaker A.
  - (4) The water in beaker B has the same temperature as the water in beaker C.
29. The set-up below shows a method to open the stuck metal lid on a glass jar by heating the metal lid with a lighter.

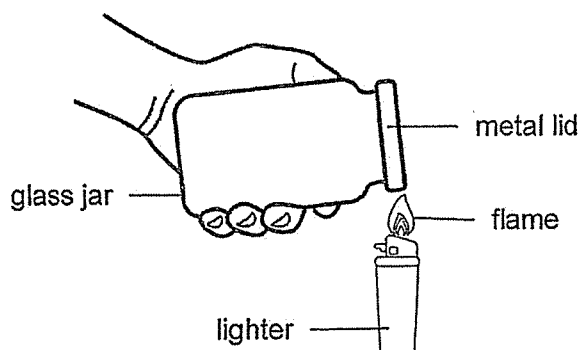

Why was the metal lid easier to open after it was heated for some time?

- (1) The metal lid softened when it was heated.
- (2) The metal lid expanded more than the glass jar.
- (3) Metal is a better conductor of heat than the glass.
- (4) The air in the jar expanded in volume and pushed the metal lid open.

30. A datalogger was used to record the temperature of water when ice cubes were added to it.

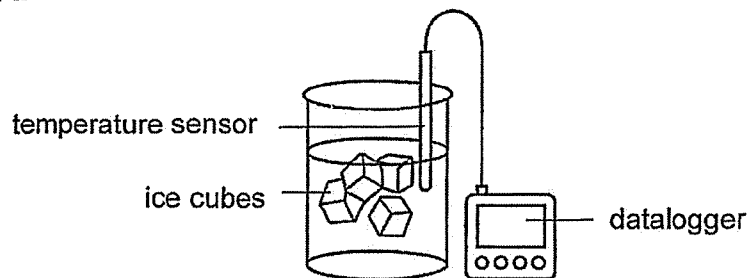

The readings were taken every minute for ten minutes and recorded in the graph below.

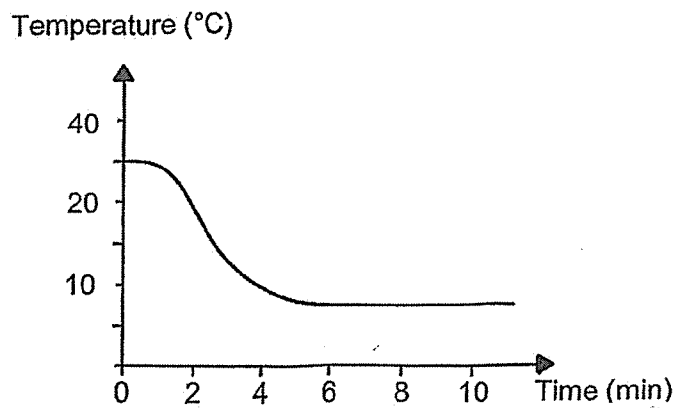

Which of the following explains the change in temperature shown on the graph?

- (1) The water lost heat to the ice cubes.
- (2) The ice cubes lost heat to the water.
- (3) The water gained heat from the ice cubes.
- (4) The ice cubes and water gained heat from the surroundings.

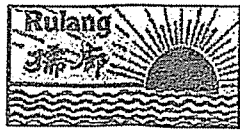

# Rulang Primary School

## END OF YEAR EXAMINATION SCIENCE 2025

Name: \_\_\_\_\_ ( ) Marks: \_\_\_\_\_ / 40

Level: Primary 5

Date: 23 Oct 2025

Class: Primary 5 ( )

### BOOKLET B

#### Instructions to pupils:

1. Do not open this booklet until you are told to do so.
2. You are required to answer all the questions in this paper using your own words / expressions as far as possible.
3. All drawings / diagrams must be clearly shown and labelled.
4. Marks will be deducted for wrongly spelt key words.
5. This question booklet consists of 

14
----

 printed pages, including the cover page.

**Section B (40 marks)**

Write your answers to questions 31 to 41 in this booklet.

31. The diagram below shows the process of fertilisation during human reproduction. X and Y are necessary for this process to take place.

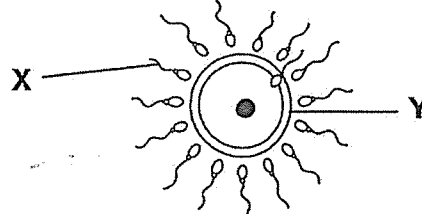

- (a) Identify X and Y. [1]

X: \_\_\_\_\_

Y: \_\_\_\_\_

- (b) The diagram below shows the parts of the reproductive systems of a human and a plant.

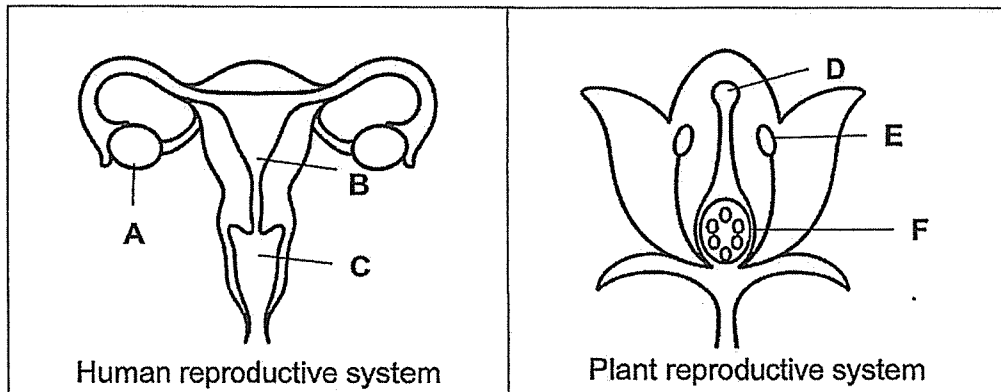

Identify the parts where the fertilised egg will develop in the human and plant reproductive systems respectively. Write the letters that represent the parts in the boxes below. [2]

	Reproductive system	Letter that represents the part
(i)	Human	
(ii)	Plant	

32. A farmer planted fruit trees in rows as shown below.

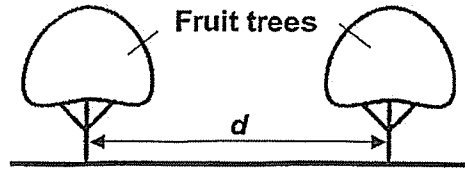

The trees were planted in rows at different distances between each tree. The farmer recorded the distances between the trees and the average number of fruits produced by each tree in one growing season, as shown in the table below.

Distance ( $d$ ) between the trees (m)	2	3	4	5	6
Number of fruits produced per tree	20	30	45	60	65

- (a) Based on the table, what is the relationship between the distance between the trees and the number of fruits produced per tree? [1]

---

---

- (b) Explain why the trees produce fewer fruits when they are too near to one another. [1]

---

---

- (c) The trees bear fruit that are sweet, juicy and brightly-coloured. Its seeds are small and hard as shown below.

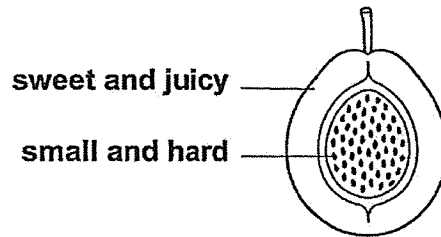

sweet and juicy

small and hard

Describe how the seeds are dispersed.

[2]

---

---

---

33. Lina hung some clothes to dry on a bamboo pole in her kitchen as shown in diagram 1. Half an hour later, her father moved the clothes outside the windows as shown in diagram 2.

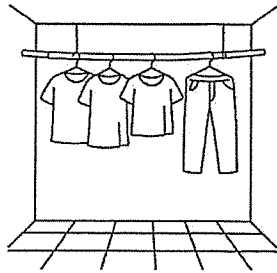

Diagram 1

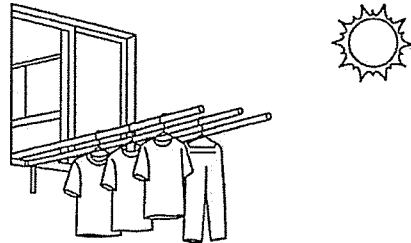

Diagram 2

- (a) Water changed its state while the wet clothes were drying. State the process.

[1]

---

- (b) Explain how the actions by her father would help the clothes dry in a shorter time.

[1]

---

---

- (c) Lina wanted to wear one of her favourite blouses in diagram 1 but it was still damp. She decided to iron it to dry it faster.

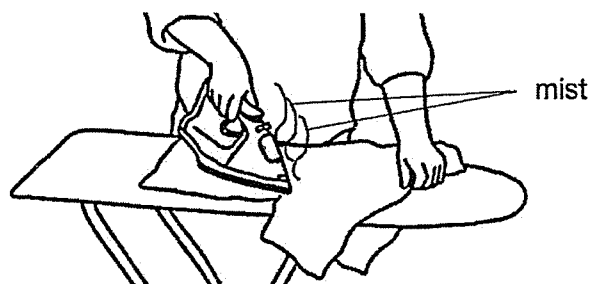

- While ironing it, she saw some mist form above the blouse. Explain how the mist was formed.

[2]

---

---

---

34. Hakim conducted an experiment to obtain water. He hung an iron rod from a string so that it could move about freely as shown below.

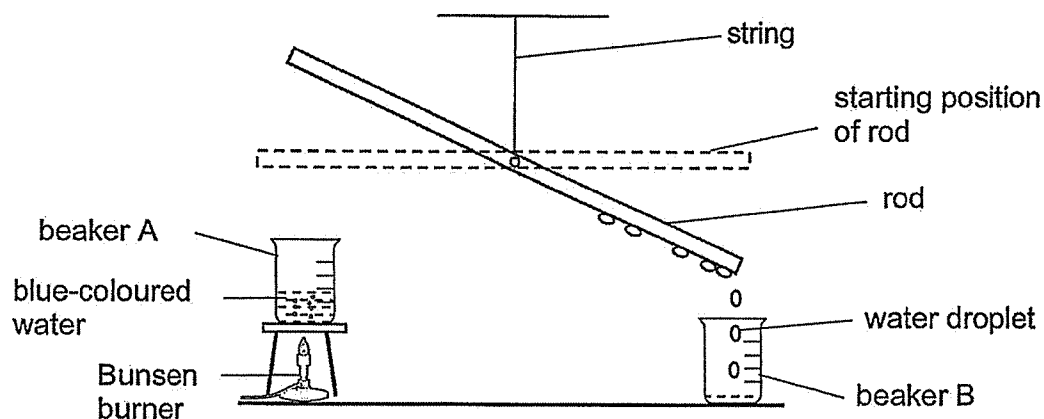

One end of the iron rod was directly above beaker A. The blue-coloured water in beaker A started to boil after a while. The rod tilted on the right, and water droplets were collected in beaker B.

- (a) What would be the colour of the water collected in beaker B? [1]

---

- (b) Explain why the glass rod tilted downwards. [2]

---

---

---

- (c) Suggest one way Hakim could increase the amount of water collected in beaker B without changing the set-up. [1]

---

---

○

35. Farmers sometimes remove food-carrying tubes from the stem of a plant to make the fruits bigger and juicier in a technique called girdling.

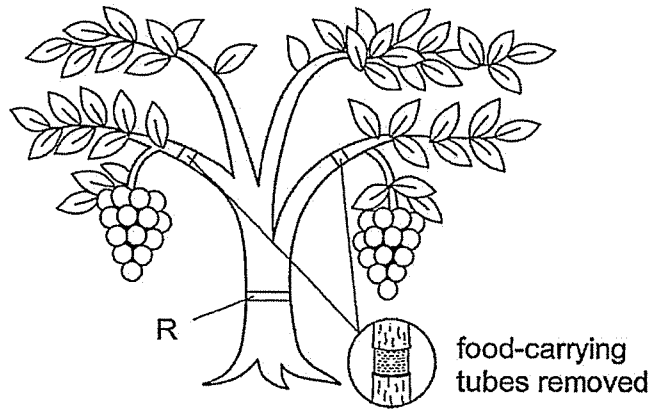

- (a) Explain how girdling helps farmers get bigger fruits. [2]

---

---

---

- (b) A farmer wants to remove the food-carrying tubes at R. Explain why this is not a good idea in the long run. [2]

---

---

---

36. Study the classification chart below.

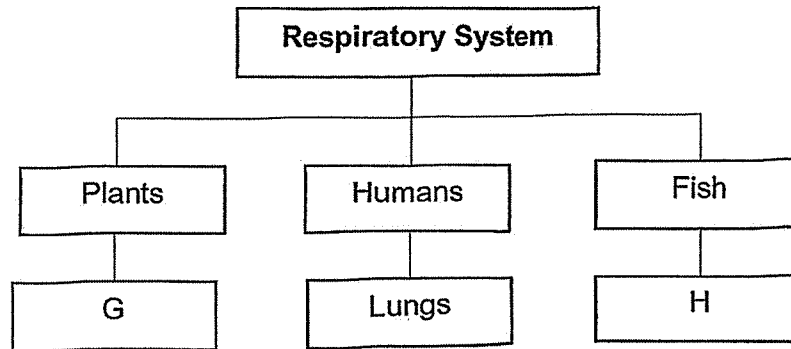

(a) Identify parts G and H.

[1]

G: \_\_\_\_\_

H: \_\_\_\_\_

(b) Explain how part H enables the fish to survive underwater but it does not work for humans when they use their lungs. [2]

---

---

---

37. Walter set up electrical circuits 1 to 4 using identical batteries and identical bulbs. The batteries and bulbs are all working properly.

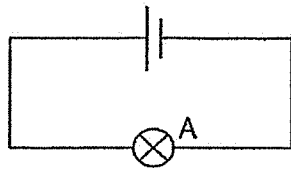

Circuit 1

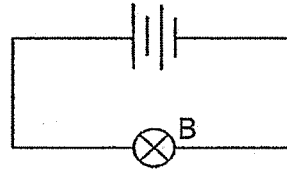

Circuit 2

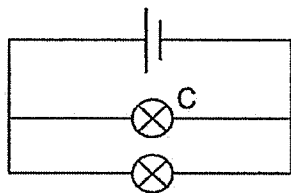

Circuit 3

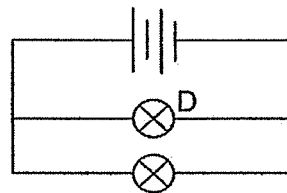

Circuit 4

Group bulbs A, B, C and D in the table below to show their brightness. [2]

Brightly-lit bulb(s)	Dimly-lit bulb(s)

38. Alicia constructed a circuit card. The diagram below shows the circuit card with points P, Q, R and S. Four of the points were connected with wires hidden behind the card.

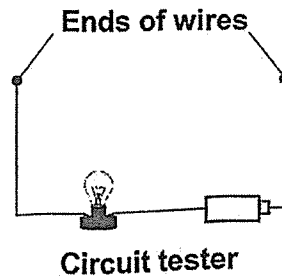
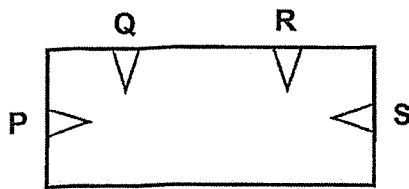

The circuit card was tested with a circuit tester. The ends of the wires of the circuit tester were connected to two points at a time. The table below shows the results.

Pair of points tested	Bulb lit up	Bulb did not light up
P and Q		
P and R		
R and S		

- (a) From the results above, draw two lines in the diagram below to show how Alicia connected the points with wires. [2]

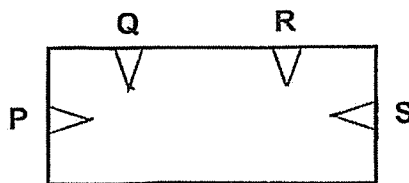

- (b) Explain why the bulb did not light up when the wires were connected to P and R. [2]

---



---



---

Alicia placed a metal ruler between Q and R on the circuit card as shown in the diagram below.

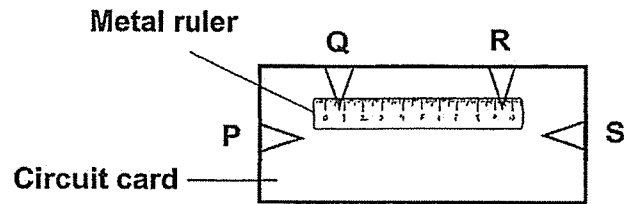

- (c) She connected the wires of the circuit tester to Q and R. Do you think the bulb would light up? Give a reason for your answer. [1]

---

---

39. Megan glued two identical jars, E and F, to a beam balance. She pumped  $600\text{cm}^3$  of air into each jar, as shown below.

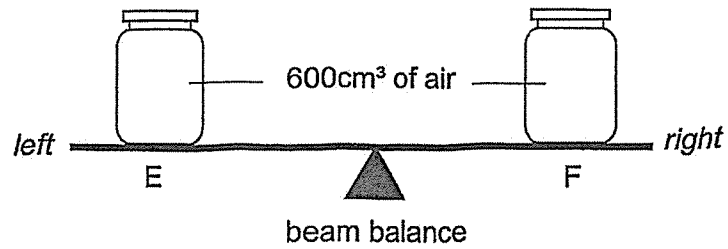

- (a) Megan then removed  $200\text{cm}^3$  of air from jar E. Describe what she would observe about the beam balance. Explain your answer. [2]

---

---

---

- (b) Megan pumped out another  $50\text{cm}^3$  from jar E. What would the volume of air in jar E be now? Explain your answer. [2]

---

---

---

40. A light source was shone on the pupils' hands to form shadows on a screen.

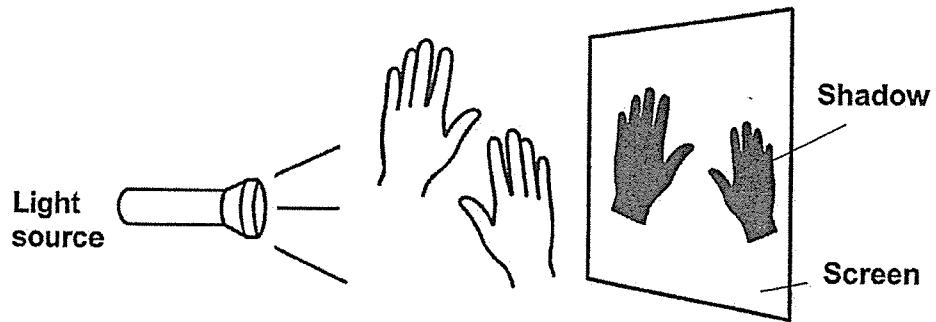

- (a) The pupils moved their hands closer to the light source. How would the sizes of the shadows change? Explain your answer. [1]

---



---

- (b) The pupils replaced their hands with different materials and recorded the shadows formed on the screen. Complete the table below by stating the shadow observed and the property of each material. [2]

Material	Shadow observed	Property of material
Cardboard	Dark shadow	
Coloured plastic sheet	Faint shadow	
Clear glass		Allows most light to pass through
Aluminium foil		Allows no light to pass through

41. The diagram below shows three identical cups made of different materials, A, B and C, on a food warmer. Each cup had the same amount of water at first.

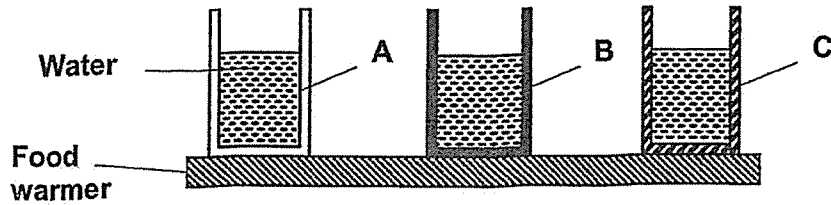

After 30 minutes, the amount of water left in each cup is as shown below.

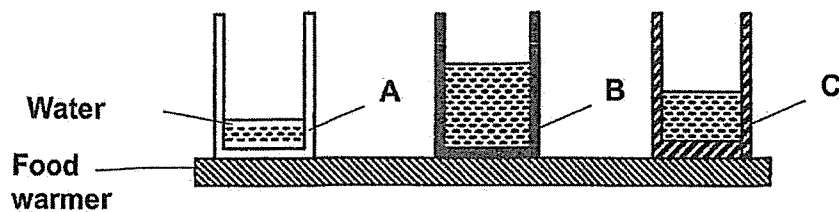

- (a) Based on the results above, what can you conclude about the property of material B? Explain your answer. [2]

---



---



---

The diagram below shows a rice cooker. The rice cooker has an inner pot and an outer body.

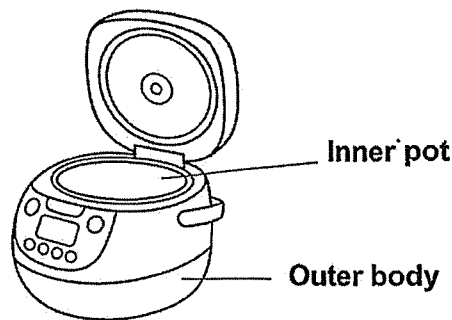

- (b) Based on the results above, which material, A, B or C, is most suitable to make the inner pot of a rice cooker? Explain your answer. [2]

---



---



---

END OF PAPER

**SCHOOL : RULANG PRIMARY SCHOOL**  
**LEVEL : PRIMARY 5**  
**SUBJECT : SCIENCE**  
**TERM : 2025 END OF YEAR EXAMINATION**

Q1	Q2	Q3	Q4	Q5	Q6	Q7	Q8	Q9	Q10
3	4	3	4	4	1	1	4	1	2
Q11	Q12	Q13	Q14	Q15	Q16	Q17	Q18	Q19	Q20
2	4	2	2	3	2	1	1	3	4
Q21	Q22	Q23	Q24	Q25	Q26	Q27	Q28	Q29	Q30
3	4	2	4	3	1	3	1	2	1

Q31	<p>a)</p> <p>X: sperm cell</p> <p>Y: egg cell</p> <p>b)</p> <p>i) B    ii) F</p>
Q32	<p>a) The more distance between the trees the more the number of fruits produced per tree.</p> <p>b) As the trees will compete for water, light and mineral salts when they are to one another as the trees will not receive a lot of light, water and mineral salts.</p> <p>c) The seeds are dispersed by animals the animal will be attracted by the brightly-coloured fruit and the animals will eat the sweet and juicy fruit and will spit out the seeds when eating the fruit.</p>
Q33	<p>a) Evaporation</p> <p>b) More heat from the sun outdoor can increase the rate of evaporation.</p> <p>c) The mist was formed when the hot iron came into contact with the damp blouse. The water absorbed heat from the iron and began to forming mist.</p>
Q34	<p>a) Colourless</p>

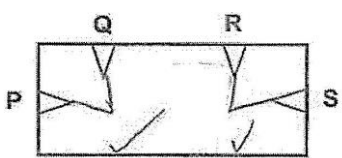
	<p>b) When the blue-coloured water in the beaker started to evaporate, the warm water vapour came into contact with the cold iron rod, lost heat, and condensed into water droplets. These droplets have mass, so they moved downward, causing the iron rod to tilt.</p> <p>c) Increase the amount of heat.</p>
Q35	<p>a) Food from the leaves cannot be transported to other parts of the plant, Thus food is stored in the fruit.</p> <p>b) When the food-carrying tubes are removed at R, the food made by the leaves cannot be transported to the roots. Without food, the roots may begin to die, and water will not be absorbed, causing the plant to wilt or die.</p>
Q36	<p>a)</p> <p>G: tiny openings</p> <p>H: gills</p> <p>b) Gills can take in oxygen in water, which the lungs can only taken oxygen from the surrounding air.</p>
Q37	B,D / A,C
Q38	<p>a)</p>  <p>b) As P and R were not connected by any wire.</p> <p>c) Yes as metal is a conductor of electricity and will allow the current to flow through.</p>
Q39	<p>a) The left side with jar E will more up, because jar E contained less air and thus less mass.</p> <p>b) 600cm<sup>3</sup>, as air has no definite to volume.</p>
Q40	<p>a) The light will increase as it blocks a more light.</p>

b)

Material	Shadow observed	Property of material
Cardboard	Dark shadow	Allows no light to pass through
Coloured plastic sheet	Faint shadow	Allows some light to pass through
Clear glass	Faint shadow	Allows most light to pass through
Aluminium foil	Dark shadow	Allows no light to pass through

Q41

a) The property of material B is an insulator of heat. As the amount of water in B did not change.

b) Material A. It is the best conductor of heat as it conducts heat the faster to cook the rice.

